

# AIRTECH<sup>®</sup> VACUUM

## Operating and Maintenance Instructions 3BA Regenerative Blowers



# INSTALLATION & OPERATING MANUAL 3BA REGENERATIVE BLOWERS

## Table of Contents

<b>Section:</b>	<b>Page Number:</b>
<b>1. Pump Ranges</b>	3
Table 1: 3 Phase, Single Stage, 50 Hertz	5
Table 2: 3 Phase, Single Stage, 60 Hertz	6
Table 3: 3 Phase, Two/Three Stage, 50 Hertz	7
Table 4: 3 Phase, Two/Three Stage, 60 Hertz	8
Single Stage – Approx. Temperature Rise	10
Two/Three Stage – Approx. Temperature Rise	11
Tightening Torque Specifications	12
<b>2. Installation</b>	14
Installation Procedure	15
<b>3. Start-up</b>	17
<b>4. Maintenance and Servicing</b>	18
Troubleshooting Chart	19
Lifting	21
Storage	22
Disposal	22
<b>5. Exploded-View Drawings</b>	23
3BA1 Single-Stage	23
3BA1 Two-Stage	24
3BA7 Single-Stage	25
3BA7 Two-Stage	26
<b>Warranty Statement</b>	27

## 1. Pump Ranges

These operating instructions cover the Airtech 3BA side channel vacuum pumps and compressors supplied with standard TEFC motors. Other configurations are available including V-belt driven units, units with explosion proof motors, mechanical seals, magnetic drives, coatings and modifications for high pressure service. Airtech can provide any combination of modifications to meet your application requirements. Such blowers, however, are outside the scope of this manual.

### Description

All regenerative blowers are dynamic compression devices and utilize a non-contacting impeller to accelerate the gas and a specially designed housing to compress the gas. Cooling is accomplished by using the motor fan to blow air over the housing. In larger models, the housing is specially designed with cooling fins to allow a wider range of operation. Both the inlet and outlet ports have built-in silencers and mesh screens. Both the inlet and outlet have an inside connection thread corresponding to DIN ISO 228. On larger units, multiple suction and discharge connection configurations may be available.

The wetted parts are constructed of Aluminum on all models. The blower shares a bearing with the motor. The seal between the bearing and the motor is not gas tight in most models, therefore these blowers are not recommended for handling of toxic or explosive gases. (Contact Airtech Vacuum, Inc. for additional options if explosive or toxic gases will be handled.)

A full range of accessory items are available, including vacuum or pressure relief valves, check valves, suction filters, motor starters, vacuum/pressure cross-over valves, and in-line filters.

### Application/Installation Environment

**CAUTION! These blowers are designed for use in general industry. Suitable personnel protection according to OSHA requirements is provided, but the equipment should not be operated in residential settings.**

Airtech blowers can be operated as either vacuum pumps or compressors. They are suitable for use with air having a relative humidity up to 90 percent, but not generally suitable for handling corrosive or erosive gases. Special versions for toxic or aggressive gases may be available. Use of the standard blower in aggressive environments may cause damage to the blower or exposure to gases being handled in the local environment.

**CAUTION! Dangerous (flammable or explosive) or aggressive (corrosive) gases should not be handled by the standard blower.**

Handling of flammable or aggressive gases and vapors may be possible by using a specially configured or modified blower. Contact factory for additional information. The standard blower is not suitable for operation in explosive environments as defined by NFPA 70. Contact factory for assistance.

**CAUTION! The ambient and suction temperatures should be between 40 and 105 F. For temperatures outside this region, please contact the factory.**

The maximum permissible pressure difference for vacuum or pressure is dependant on the motor rating (See Tables 1 to 4 for detailed information by model number.) and power supply frequency. The figures in Tables 1 to 4 are computed assuming an ambient temperature of 77 F (25 C) and a local barometric pressure of 1013 mbar (sea level). Operation at an ambient temperature of 104 F (40C) is the maximum permissible, and will result in a reduction of 10 percent on maximum vacuum or pressure attainable by the unit. For temperatures between 77 F and 104 F, reduce the maximum pressure reduction is a linear function of temperature.

Table 1. Three-phase, Single Stage, 50 Hertz

Model	Rated Power HP/kW	Voltage	Motor Current (Amps)	Open Flow Capacity CFM/m3/hr	Maximum Pressure (mbar)	Sound Pressure Level (dBA)
3BA1300-7AT06	.33/.25	200-240/345-415	2.1/1.2	48/82	-100/100	53
2BA1300-7AT16	.54/.4	200-240/345-415	2.6/1.5	48/82	-120/130	53
3BA1400-7AT06	.94/.7	200-240/345-415	3.8/2.2	84/142	-120/120	63
2BA1400-7AT16	1.15/.85	200-240/345-415	4.2/2.4	84/142		63
3BA1400-7AT26	1.75/1.3	200-240/345-415	5.7/3.3	84/142	-170/200	63
3BA1500-7AT06	1.15/.85	200-240/345-415	4.2/2.4	120/204	-100/100	64
3BA1500-7AT16	1.75/1.3	200-240/345-415	5.7/3.3	120/204	-170/170	64
3BA1500-7AT26	2.15/1.6	200-240/345-415	7.5/4.3	120/204	-200/190	64
3BA1500-7AT36	2.96/2.2	200-240/345-415	9.7/5.6	120/204	-220/270	64
3BA1600-7AT06	2.15/1.6	200-240/345-415	8.5/4.9	188/320	-160/150	69
3BA1600-7AT16	2.96/2.2	200-240/345-415	9.7/5.6	188/320	-190/190	69
3BA1600-7AT26	4.04/3.0	200-240/345-415	12.5/7.2	188/320	-260/270	69
3BA1600-7AT36	5.4/4.0	200-240/345-415	13.0/7.5	188/320	-290/360	69
3BA1630-7AT06	2.15/1.6	200-240/345-415	8.5/4.9	240/408	-160/150	69
3BA1630-7AT16	2.96/2.2	200-240/345-415	9.7/5.6	240/408	-190/190	69
3BA1630-7AT26	4.04/3.0	200-240/345-415	12.5/7.2	240/408	-260/270	69
3BA1630-7AT36	5.4/4.0	200-240/345-415	15.6/9.0	240/408	-260/290	69
3BA1800-7AT06	5.4/4.0	200-240/345-415	15.6/9.0	280/476	-200/200	70
3BA1800-7AT16	7.4/5.5	200-240/345-415	23/13.3	280/476	-300/300	70
3BA1800-7AT26	10/7.5	200-240/345-415	29/16.7	280/476	-320/430	70
3BA1830-7AT06	5.4/4	200-240/345-415	15.6/9	400/680	-200/200	76
3BA1830-7AT16	7.4/5.5	200-240/345-415	23/13.3	400/680	-320/430	76
3BA1830-7AT26	10/7.5	200-240/345-415	29/16.7	400/680	-320/430	76
3BA1900-7AT06	10.8/8	200-240/345-415		568/965		74
3BA1900-7AT16	16.8/12.5	200-240/345-415	48.5/28	568/965	-290/280	74
3BA1900-7AT36	25/18.5	200-240/345-415	64.5/37	568/965		74
3BA1930-7AT16	16.8/12.5	200-240/345-415	48.5/28	744/1264	-290/280	71
3BA1930-7AT36	25/18.5	200-240/345-415	64.5/37	744/1264	-310/310	71
3BA7210-0AT167	.75/.55	200-240/345-415	2.8/1.6	28/48	-230/290	57
3BA7310-0AT167	.75/.55	200-240/345-415	2.8/1.6	40/68	-250/250	57
3BA7410-0AT167	1.5/1.1	200-240/345-415	5.4/3.1	50/84	-300/380	58
3BA7510-0AT168	2/1.5	200-240/345-415	7.5/4.3	70/120	-370/650	64
3BA7510-0AT268	3/2.2	200-240/345-415	9.7/5.6	70/120	-310/430	64
3BA7610-0AT168	3/2.2	200-240/345-415	9.7/5.6	96/163	-310/430	65
3BA7610-0AT368	4.4/3.3	200-240/345-415	13/7.5	96/163	-500/750	65

Table 2. Three-phase, Single-stage, 60 Hz

Model	Rated Power HP/kW	Voltage	Motor Current (Amps)	Open Flow Capacity CFM/m <sup>3</sup> /hr	Maximum Pressure (mbar)	Sound Pressure Level (dBA)
3BA1300-7AT06	.39/.29	220-250/415-460	1.74/1.0	60/102	-100/100	56
2BA1300-7AT16	.67/.5	220-250/415-460	2.6/1.5	60/102	-150/160	56
3BA1400-7AT06	1.12/.83	220-250/415-460	3.75/2.15	105/179	-130/130	64
3BA1400-7AT16	1.28/.95	220-250/415-460	4.35/2.5	105/179		64
3BA1400-7AT26	2/1.5	220-250/415-460	5.5/3.2	105/179	-210/200	64
3BA1500-7AT06	1.28/.95	220-250/415-460	4.35/2.5	150/255	-80/70	70
3BA1500-7AT16	2/1.5	220-250/415-460	5.5/3.2	150/255	-150/140	70
3BA1500-7AT26	2.7/2.05	220-250/415-460	7.5/4.4	150/255	-220/210	70
3BA1500-7AT36	3.4/2.55	220-250/415-460	9.0/5.3	150/255	-260/290	70
3BA1600-7AT06	2.7/2.05	220-250/415-460	7.5/4.4	235/400	-160/150	72
3BA1600-7AT16	3.4/2.55	220-250/415-460	9.0/5.3	235/400	-190/190	72
3BA1600-7AT26	4.6/3.45	220-250/415-460	12.0/6.5	235/400	-240/230	72
3BA1600-7AT36	6.1/4.6	220-250/415-460	15.2/8.5	235/400	-320/310	72
3BA1630-7AT06	2.7/2.05	220-250/415-460	7.5/4.4	300/510	-160/150	72
3BA1630-7AT16	3.4/2.55	220-250/415-460	9.0/5.3	300/510	-190/190	72
3BA1630-7AT26	4.6/3.45	220-250/415-460	12.0/6.5	300/510	-240/230	72
3BA1630-7AT36	6.1/4.6	220-250/415-460	15.2/8.5	300/510	-260/260	72
3BA1800-7AT06	6.1/4.6	220-250/415-460	15.2/8.5	350/595	-160/160	74
3BA1800-7AT16	8.4/6.3	220-250/415-460	20/11.2	350/595	-300/280	74
3BA1800-7AT26	11.5/8.6	220-250/415-460	27.5/15	350/595	-350/400	74
3BA1830-7AT06	6.4/4.6	220-250/415-460	15.2/8.5	500/850	-160/160	79
3BA1830-7AT16	8.4/6.3	220-250/415-460	20/11.2	500/850	-300/280	79
3BA1830-7AT26	11.5/8.6	220-250/415-460	27.5/15	500/850	-350/400	79
3BA1900-7AT06	12.1/9	220-250/415-460		710/1207		79
3BA1900-7AT16	19.5/14.5	220-250/415-460	50/29	710/1207	-270/260	79
3BA1900-7AT36	28.7/21.3	220-250/415-460	68/39	710/1207		79
3BA1930-7AT16	19.5/14.5	220-250/415-460	50/29	930/1581	-270/260	75
3BA1930-7AT36	28.7/21.3	220-250/415-460	68/39	930/1581	-300/280	75
3BA7210-0AT167	1.1/.83	220-250/415-460	3.75/2.15	35/60	-270/320	62
3BA7310-0AT167	1.1/.83	220-250/415-460	3.75/2.15	48/82	-260/250	62
3BA7410-0AT167	2/1.5	220-250/415-460	5.5/3.2	60/102	-340/370	62

When operating at altitudes above 3280 feet (1000 m) above mean sea level, contact Airtech Inc.

**CAUTION! Operation of the unit outside the recommended range of pressures and ambient conditions will result in shorted operating life.**

Table 3. 3 Phase, Two/Three Stage, 50 Hertz

Model	Rated Power HP/kW	Voltage	Motor Current (Amps)	Open Flow Capacity CFM/m3/hr	Maximum Pressure (mbar)	Sound Pressure Level (dBA)
3BA1310-7AT26	.94/1.7	200-240/345-415	3.8/2.2	48/81.6	-120/120	55
3BA1410-7AT36	2.15/1.6	200-240/345-415	7.5/4.3	84/142.8	-200/190	66
3BA1410-7AT46	2.96/2.2	200-240/345-415	9.7/5.6	84/142.8	-320/420	66
3BA1510-7AT46	4.04/3.0	200-240/345-415	12.5/7.2	121.6/206.7	-340/410	72
3BA1510-7AT56	5.39/4.0	200-240/345-415	17.4/10	121.6/206.7	-390/440	72
3BA1610-7AT36	2.9/2.2	200-240/345-415	9.7/5.6	188/319.6	-190/190	73
3BA1610-7AT26	4.04/3.0	200-240/345-415	12.5/7.2	188/319.6	-260/270	73
3BA1610-7AT36	5.39/4.0	200-240/345-415	13.0/7.5	188/319.6	-290/360	73
3BA1610-7AT46	7.41/5.5	200-240/345-415	23/13.3	188/319.6	-420/500	73
3BA1610-7AT56	10.1/7.5	200-240/345-415	29/16.7	188/319.6	-420/610	73
3BA1640-7AT36	5.39/4.0	200-240/345-415	13.0/7.5	280/476	-290/360	74
3BA1640-7AT46	7.41/5.5	200-240/345-415	23/13.3	280/476	-420/500	74
3BA1640-7AT56	10.1/7.5	200-240/345-415	29/16.7	280/476	-420/610	74
3BA1810-7AT16	7.4/5.5	200-240/345-415	23/13.3	280/476	-420/500	74
3BA1810-7AT26	10.1/7.5	200-240/345-415	29/16.7	280/476	-320/430	74
3BA1810-7AT36	14.8/11	200-240/345-415	29/16.7	280/476	-430/600	74
3BA1810-7AT46	20.2/15	200-240/345-415	56.5/32.5	280/476	-460/670	74
3BA1840-7AT26	10.1/7.5	200-240/345-415	29.0/16.7	280/476	-320/430	74
3BA1840-7AT36	14.8/11.0	200-240/345-415	48.5/28.0	280/476	-430/600	74
3BA1910-7AT16	16.8/12.5	200-240/345-415	48.5/28	624/1061	-290/280	74
3BA1910-7AT36	26.95/20.	200-240/345-415	-	624/1061	-	74
3BA7220-0AT567	2/1.5	200-240/345-415	7.5/4.3	28/48	-370/650	58
3BA7320-0AT467	1.5/1.1	200-240/345-415	5.4/3.1	40/68	-300/380	58
3BA7320-0AT567	2/1.5	200-240/345-415	7.5/4.3	40/68	-480/450	59
3BA7420-0AT267	2/1.5	200-240/345-415	7.5/4.3	50/84	-480/450	61
3BA7420-0AT567	4.4/3.3	200-240/345-415	13/7.5	50/84	-500/750	61
3BA7520-0AT268	3/2.2	200-240/345-415	9.7/5.6	70/120	-470/460	64
3BA7620-0AT368	4.4/3.3	200-240/345-415	13/7.5	96/163	-500/750	68
3BA7620-0AT468	5.4/4	200-240/345-415	14/8.1	96/163	-370/650	67
3BA7620-0AT568	7.5/5.5	200-240/345-415	19.9/11.5	96/163	-520/750	68
3BA7630-0AT668	10.1/7.5	200-240/345-415	29/16.7	96/163	-420/610	77

Table 4. 3 Phase, Two/Three Stage, 60 Hertz

Model	Rated Power HP/kW	Voltage	Motor Current (Amps)	Open Flow Capacity CFM/m <sup>3</sup> /hr	Maximum Pressure (mbar)	Sound Pressure Level (dBA)
3BA1310-7AT26	1.11/1.83	220-250/415-460	3.75/2.15	60/102	-130/130	61
3BA1410-7AT36	2.7/2.05	220-250/415-460	7.5/4.4	105/179	-220/210	69
3BA1410-7AT46	3.4/2.55	220-250/415-460	9.0/5.3	105/179	-350/440	69
3BA1510-7AT46	4.6/3.45	220-250/415-460	12.0/6.5	152/258	-380/360	74
3BA1510-7AT56	6.1/4.6	220-250/415-460	15.2/8.5	152/258	-410/480	74
3BA1610-7AT36	3.4/2.55	220-250/415-460	9.0/5.3	235/400	-190/190	76
3BA1610-7AT26	4.6/3.45	220-250/415-460	12.0/6.5	235/400	-240/230	76
3BA1610-7AT36	6.4/4.8	220-250/415-460	16.5/9.8	235/400	-320/310	76
3BA1610-7AT46	8.4/6.3	220-250/415-460	20/11.2	235/400	-440/440	76
3BA1610-7AT56	11.5/8.6	220-250/415-460	27.5/15.0	235/400	-440/670	76
3BA1640-7AT36	6.1/4.6	220-250/415-460	15.2/8.5	350/595	-320/310	78
3BA1640-7AT46	8.4/6.3	220-250/415-460	20.0/11.2	350/595	-440/440	78
3BA1640-7AT56	11.5/8.6	220-250/415-460	27.5/15.0	350/595	-440/670	78
3BA1810-7AT16	8.4/6.3	220-250/415-460	20.0/11.2	350/595	-440/440	78
3BA1810-7AT26	11.5/8.6	220-250/415-460	27.5/15.0	350/595	-350/400	78
3BA1810-7AT36	17/12.6	220-250/415-460	50.2/29.0	350/595	-460/600	78
3BA1810-7AT46	23.3/17.3	220-250/415-460	60.0/34.5	350/595	-490/750	78
3BA1840-7AT26	11.5/8.6	220-250/415-460	27.5/15.0	350/595	-350/400	78
3BA1840-7AT36	17/12.6	220-250/415-460	50.2/29.0	350/595	-460/600	78
3BA1910-7AT16	19.5/14.5	220-250/415-460	50.0/29.0	780/1326	-270/260	84
3BA1910-7AT36	31/23	220-250/415-460	--- / ---	780/1326	--- / ---	84
3BA7220-0AT567	2.7/2.05	220-250/415-460	7.5/4.4	35/60	-500/740	62
3BA7320-0AT467	2/1.5	220-250/415-460	5.5/3.2	48/82	-340/370	63
3BA7320-0AT567	2.7/2.05	220-250/415-460	7.5/4.4	48/82	-430/410	63
3BA7420-0AT267	2.7/2.05	220-250/415-460	7.5/4.4	60/102	-430/410	66
3BA7420-0AT567	5.1/3.8	220-250/415-460	13.5/7.8	60/102	-510/850	66
3BA7520-0AT268	3.4/2.55	220-250/415-460	9/5.3	84/143	-500/450	70
3BA7620-0AT368	5.1/3.8	220-250/415-460	13.5/7.8	115/196	-510/850	71
3BA7620-0AT468	6.1/4.6	220-250/415-460	15.2/8.5	115/196	-480/500	71
3BA7620-0AT568	8.4/6.6	220-250/415-460	22.5/12.6	115/196	-520/820	72
3BA7630-0AT668	11.5/8.6	220-250/415-460	27.5/15	115/196	-440/670	80



Operation of any blower is possible at 87 Hertz without modification. When using a VFD to operate the blower at this frequency, refer to the nameplate for limits on vacuum and pressure, current draw and motor performance.

If your specific model number is not listed above, please consult the nameplate on the unit for electrical data. If the model you are installing is listed above, please confirm the data on the nameplate. Data in Tables 1 through 4 is subject to change and is approximate. Be sure to confirm necessary operating data what that on the nameplate before commissioning the unit.

**CAUTION! Do not operate any 3BA blower above 87 Hz without consultation with the factory. Failure of the blower motor is possible when operating out of range. Consult with the factory for assistance.**

Expected temperature rise of the handled gas at maximum allowable pressure differential and when operating at sea level is indicated below:

Single Stage – Approximate Temperature Rise

Blower Model	Maximum Rise at 50 Hz speed		Maximum Rise at 60 Hz speed	
	Degrees F	Degrees K	Degrees F	Degrees K
3BA1100-7..0.	115	46	136	58
3BA1200-7..0.	65	18	101	38
3BA1300-7..0.	90	32	77	25
3BA1300-7..1.	90	32	140	60
3BA1300-7..2.	90	32	158	70
3BA1400-7..0.	99	37	86	30
3BA1400-7..1.	129	54	122	50
3BA1400-7..2.	149	65	167	75
3BA1500-7..0.	86	30	72	22
3BA1500-7..1.	115	46	97	36
3BA1500-7..2.	138	59	122	50
3BA1500-7..3.	203	95	180	82
3BA1500-7..6.	248	120	248	120
3BA1600-7..0.	81	27	68	20
3BA1600-7..1.	145	63	104	40
3BA1600-7..2.	171	77	176	80
3BA1600-7..3.	225	107	185	85
3BA1600-7..6.	248	120	194	90
3BA1600-7..7.	248	120	248	120
3BA1800-7..0.	104	40	104	40
3BA1800-7..1.	153	67	185	85
3BA1800-7..2.	248	120	221	105
3BA1900-7..0.	97	36	95	35
3BA1900-7..0.	182	83	155	68
3BA1900-7..0.	230	110	212	100
3BA7210-0..1..	126	52	142	61
3BA7310-0..1..	142	61	142	61
3BA7310-0..2..	178	81	187	86
3BA7410-0..1..	194	90	214	101
3BA7510-0..1..	199	93	232	111
3BA7510-0..2..	248	120	234	112
3BA7610-0..1..	244	118	255	124
3BA7610-0..3..	244	118	255	124

Two/Three Stage – Approximate Temperature Rise

Blower Model	Maximum Rise at 50 Hz speed		Maximum Rise at 60 Hz speed	
	Degrees F	Degrees K	Degrees F	Degrees K
3BA1310-7..2.	127	53	165	74
3BA1410-7..3.	154	68	149	65
3BA1410-7..4.	181	83	180	82
3BA1510-7..4.	190	88	176	80
3BA1510-7..5.	194	90	201	94
3BA1610-7..1.	92	33	86	30
3BA1610-7..2.	129	54	118	48
3BA1610-7..3.	176	80	167	75
3BA1610-7..4.	221	105	190	88
3BA1610-7..5.	246	120	266	130
3BA1610-7..7.	176	80	167	75
3BA1610-7..8.	176	80	248	120
3BA1810-7..1.	113	45	-	-
3BA1810-7..2.	185	85	140	60
3BA1810-7..3.	248	120	248	120
3BA1910-7..1.	119	48	115	46
3BA1910-7..2.	203	95	169	76
3BA1910-7..3.	248	12	274	134
3BA7220-0..2..	131	55	171	77
3BA7220-0..5..	165	74	230	110
3BA7320-0..5..	178	81	255	124
3BA7420-0..2..	192	89	176	80
3BA7420-0..5..	250	121	243	117
3BA7520-0..2..	192	89	216	102
3BA7520-0..7..	257	125	230	110
3BA7620-0..3..	255	124	259	126
3BA7620-0..5..	255	124	262	128
3BA7630-0..6..	248	120	248	120

## Tightening Torque Specifications

For non-electrical connections

Thread	Ft-lbs maximum torque	Nm maximum torque
M4	2.43	3.3
M5	3.25	4.4
M6	6.49	8.8
M8	19.47	26.4
M10	34.10	46.2
M12	56.76	77

For electrical connections

Thread	Ft-lbs torque	Nm torque
M4	0.6 to 0.9	0.8 to 1.2
M5	1.3 to 1.8	1.3 to 1.8

For metal threaded glands/unions

Thread	Ft-lbs maximum torque	Nm maximum torque
M12x1.5	3 to 4.5	4 to 6
M16x1.5	3.7 to 5.5	5 to 7.5
M20x1.5	4.4 to 6.6	6 to 9
M32x1.5	5.9 to 8.9	8 to 12
M40x1.5	5.9 to 8.9	8 to 12

For plastic threaded glands/unions

Thread	Ft-lbs maximum torque	Nm maximum torque
M12x1.5	1.5 to 2.6	2 to 3.5
M16x1.5	2.2 to 3	3 to 4
M20x1.5	3 to 3.7	4 to 5
M32x1.5	3.7 to 5.2	5 to 7
M40x1.5	3.7 to 5.2	5 to 7

Operating above the indicated maximum pressure or vacuum would overload the motor and/or overheat the unit. In addition to the maximum allowable pressure difference, careful consideration should be given to matching the motor protection devices (provided by others) to the expected current draw. In no case should the blower be operated with inadequate motor overload protection.

Since regenerative blowers are dynamic compression devices, the performance limits shown in Tables 1 to 4 are applicable only for a gas with the same specific gravity, dynamic viscosity and chemical characteristics as air. For gases with different physical properties than air, the limits will be different from those shown in the tables. Please contact Airtech for assistance in determining the proper blower size and configuration if handling gases other than air.

A vacuum relief valve or pressure relief valve should always be installed at the suction or discharge of the regenerative blower. This will prevent operation outside the applicable ranges shown in Tables 1 to 4. If the relief valves were not specified in the ordering process, please contact Airtech for details, price and availability of the needed valves before commissioning the unit. Failure to use the proper relief valve may result in failure of the blower due to operation outside the applicable limits; any such failure is outside the scope of Airtech's standard warranty.

**WARNING! Be sure to install the necessary personnel protection devices if unexpected shut-down of the unit presents danger of death or injury.**

## 2. Installation

As illustrated in Figure 1, the Airtech 3BA blower can be installed in any physical configuration.

**CAUTION! Regenerative blowers can have surface temperatures in excess of 120 F. To avoid burns or other physical injury, take care to avoid contact with the surfaces of the blower during and immediately after operation.**

To ensure adequate cooling of the blower during operation, install the blower with the minimum clearance as indicated in the table below.

Minimum installation clearances, 3BA blowers

Range	Distance from fan guard to closest obstruction. (inches/mm)	Distance from cover (opposite of fan) to closest obstruction. (inches/mm)
3BA11 through 3BA14	1.4/34	0.79/20
3BA15 through 3BA19	2.1/53	1.57/40
3BA72 and 3BA73	1.3/34	1.18/30
3BA74 through 3BA76	2.1/54	1.18/30

Please note that it may be desirable, where possible, to allow for larger clearances to allow access for maintenance or repair personnel. The noted clearances are to ensure adequate air flow for cooling only and are a minimum requirement.

Failure to allow for the noted clearances may result in premature failure of the blower due to lack of cooling, even if all other precautions are taken as recommended. For specific advice about installations requiring closer clearances, please contact Airtech, Inc. for recommendations.

Airtech regenerative blowers can be mounted in any configuration, either horizontally or vertically mounted. It is not usually necessary to bolt the smaller blowers to a rigid surface during operation, though this may be desirable to reduce pipe vibration, movement and noise. Larger models should be bolted in place, especially when installed vertically, to prevent possible rotation, damage or injury due to start-up torque.

**CAUTION! For installations at altitudes greater than 3250 Feet above sea level there will be a loss in capacity. Please contact your factory representative for assistance in determining the extent of the loss of capacity likely at your specific location.**

**WARNING! Be sure to follow all local codes and regulations with respect to installation and operation of the blower. The blower motor should be wired to a branch circuit disconnect and all other safety devices recommended by the relevant sections of NFPA 70, National Electrical Code, and in accordance with all applicable state and local regulations and requirements.**

## Installation Procedure

Perform the installation exactly in accordance with the following steps:

1. For vacuum operation, connect the suction pipe to connection A, and for pressure operation connect the pressure pipe to connection B (See Figure 1). Install startup screens before startup to protect pump from debris.

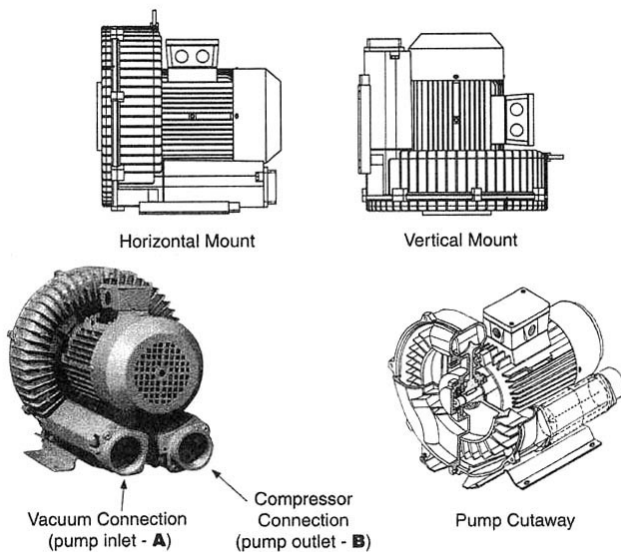

Figure 1

**CAUTION! Design your piping system to avoid unnecessary pressure loss, which may significantly affect the operation of any regenerative blower. Contact your Airtech representative for assistance in designing and configuring an appropriate piping system for your application.**

For alternation between vacuum and pressure in any application, changeover valves are available. Use of the changeover valve allows the same connection to be used for both vacuum and pressure.

2. The electrical data shown in Tables 1 to 4 should be confirmed by examination of the motor data plate on your 3BA blower. The motors feature Class F insulation as a standard and are UL recognized for applications in both Canada and the United States (CUL). Motors are IEC design IP55, equal to a NEMA TEFC motor design. The connection diagram for the motors can be found in the inside of the terminal box cover. Be sure to confirm that your electrical supply has sufficient capacity to operate the blower according to the nameplate requirements.

3. A magnetic motor starter should always be used to connect the motor to the power supply. It is advisable to use thermal overload motor starters to provide

maximum protection for the motor and wiring. All cabling used on starters should be secured with good quality cable clamps.

We recommend that the motor starters used feature a time delay trip on high amperage to avoid nuisance trips on start-up. When the unit is started cold, over amperage may be experienced for a short time due to the higher resistance of the windings at lower temperatures.

If using a change over or solenoid valve, ensure that the voltage connected to the valve matches that shown on the valve instructions or nameplate. Most valves are rated for 110 Volts 60Hz or 220 Volts 50 Hz. Connection of these valves to higher voltages may result in immediate valve failure.

**WARNING! The electrical installation should be made by a qualified electrician and in complete compliance with all NFPA 70 (National Electrical Code) requirements along with all state and local code requirements. The main disconnect and motors starters are assumed to be provided by others.**

4. Install the necessary relief valves and confirm their proper operation.



### 3. Start-up

**CAUTION! Do not start the blower motor more than 10 times in one hour. If multiple and frequent start-ups are required by your application, install a minimum run timer in the motor control circuit to avoid decreased motor life and possible fire due to over-starting of the motor.**

1. Before operation, confirm the correct direction of rotation by jogging (switching rapidly on and off) the motor and observing the motor fan rotation in the same direction as the arrow. If the direction of rotation is incorrect, lock out the power and switch two leads (three phase) or rewire (single phase) to effect the opposite rotation direction. Recheck the direction of rotation before proceeding.

2. Do not operate the blower at pressure or vacuum ranges that exceed those shown in Tables one through four for the model being installed. This can be achieved by use of the recommended relief valve shown in Table 5.

Note: Relief valves that have been factory pre-set have a label indicating the set pressure and an arrow indicating the direction of flow. The arrow will point into the pipe when installed in vacuum applications and out of the pipe when installed in pressure applications. Do not re-set the relief valve if it has been pre-set from the factory.

In the event the relief valve setting needs to be reset, adjust the set screw to increase or decrease the tension on the spring. Place the blower in operation and note the current draw of the motor. When the current draw of the motor is near the maximum noted on the motor nameplate, tighten the locking nut on the valve and proceed.

3. When checking the current draw of the motor with an ammeter, be sure to confirm the voltage at the motor junction box. Low voltage conditions may result in difficulty starting or in unexpected motor failure or motor starter trips.

#### **Potential Risks for Operators**

Noise emission: Free field noise limits are indicated in Tables one through four. Hearing protection is not normally required at the expected noise generation levels in the table; however, local conditions may result in higher ambient noise. If this is the case and local noise exceeds OSHA recommended levels for expected exposure time (typically 85 dBA for eight hours), hearing protection should be used.

#### 4. Maintenance and Servicing

**WARNING!** Be sure the power supply is disconnected and locked out before attempting to do any maintenance on the unit. It is critical that the unit be locked out from starting during maintenance as severe injury or death could result from exposure to high voltage or rotating parts.

**CAUTION!** Allow the blower to cool to a surface temperature of less than 100 F before attempting maintenance. Prolonged exposure to temperatures above 120F can cause severe burns.

Clean the blower surfaces periodically to avoid build up of dust or other debris. Build up of debris can cause overheating and premature failure of the blower.

If an inlet filter is being used, ensure that it remains clean during operation by examining the filter cartridge for debris build up. Replace dirty or clogged filter cartridges.

On pressure units, periodically clean the inlet mesh screen to avoid loss of capacity. If an external inlet filter is used, the filter element should be cleaned monthly or as frequently as required by local conditions. Excessive pressure drop will develop from use of clogged or dirty filters. This pressure drop will degrade blower performance and increase operating temperatures, leading possibly to premature pump failure.

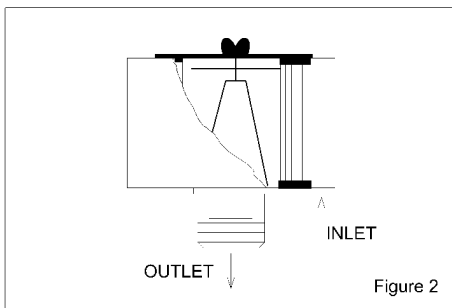

To replace the filter, remove the wing nut and cover. Remove the element and either clean with compressed air or replace. Reassemble in reverse order.

For vacuum applications, the optional in-line vacuum filter must be cleaned regularly, depending on local conditions. Cleaning can be achieved by blowing out with compressed air. If cleaning is not possible, replace the cartridge. Access the cartridge by unhooking the relevant clips and removing the cover.

**CAUTION!** Do not attempt to check the filter cartridge during operation of the blower. Only check the cartridge after disconnecting the power from the blower and locking out the power to prevent an unexpected start.

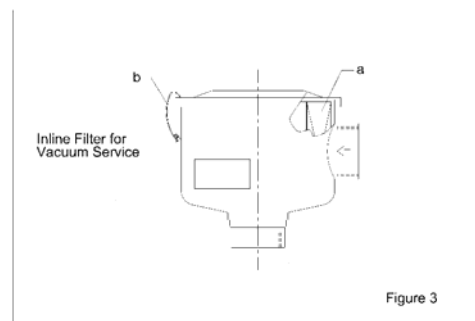

Bearings require regreasing with Exxon/Esso UNIREX N3 or equal grease after approximately 20,000 operating hours (normal conditions) or between 2 and 3 years after installation and commissioning. Do not mix grease types.

### Troubleshooting Chart

Fault	Cause	Remedy	Responsible Party
Motor does not start, no noise.	Two or more power legs interrupted	Check fuses, terminals, etc.. for source of interruption and correct.	Electrician
Motor does not start, humming noise.	One power supply lead interrupted	Check fuses, terminals, etc.. for source of interruption and correct.	Electrician
	Impeller is jammed.	Open blower cover, remove debris, clean.	Service Technician
		Check impeller clearance and reset if necessary.	
	Defective Impeller	Replace impeller.	Service Technician
Defective Bearing	Replace defective bearing.	Service Technician	
Trip of motor starter at start-up	Incorrect starter setting	Ensure starter setting is correct (check current on nameplate)	Electrician
	Winding short-circuit	Megger motor	Electrician
	Motor overloaded due to operation of pump at excessive differential pressures.	Inspect filters, mufflers and connection pipes and clean as required.  Check relief valve operation. Reset or replace as necessary.	Operator
	Impeller Jammed	See above fault Motor does not start, humming noise, cause jammed impeller.	Operator
Excessive Power Consumption	Lime or other deposits	Decalcify or clean unit as required (see Maintenance Chart)	Operator
No Vacuum or Pressure.	Severe leak in system	Close off pump and run deadheaded to confirm pump is operating properly. If so, find and fix leak in the system.	Operator
	Wrong direction of rotation	Check air flow direction and change direction of rotation if necessary.	Operator Electrician

Insufficient Vacuum	System too small	Use larger system	Operator
	Inlet piping too long or too small.	Increase pipe diameter to reduce pressure loss in inlet piping. Contact Airtech for assistance in determining correct pipe size.	Operator
	Leak at connection to vacuum system.	Check for leaks and repair if necessary.	Operator
	Density of gas handles different from air.	Consider increased limits on operation due to density differences. Consult Airtech, Inc. for assistance.	Airtech Engineering
	Change in impeller geometry due to erosion	Clean impeller and examine for wear. Replace if necessary.	Service Technician
	Inlet filter clogged.	Change filter element; remove clog.	Operator
	Vacuum relief valve incorrectly set.	Reset or replace vacuum relief valve. Contact Airtech for assistance.	Operator
	Seal defective.	Replace seal.	Service Technician
Abnormal flow noises.	Flow speed too high.	Clean pipes or use larger pipes to connect unit to process.	Operator
	Muffler soiled.	Clean muffler inserts, replace if necessary.	Operator
Abnormal running noise	Ball bearing defective or insufficient lubrication on bearing.	Re-grease or replace bearing as required.	Service Technician
Compressor leaky	Seals on muffler defective.	Tighten muffler connection. Replace gasket if necessary.	Operator
	Seals in motor area defective	Replace as necessary.	Service Technician

## Repair on-site

**WARNING! Before attempting an on-site repair, ensure that a qualified electrician has disconnected the motor from the power supply so that accidental starting of the motor is impossible.**

After a repair and before re-installation be sure to follow the instructions noted in this manual under “Installation and Operation.”

## Lifting

For smaller units (less than 65 lbs/ 30 kgs), it may be possible to lift the units manually. When doing so, be sure to understand the weight of the unit being lifted and to follow good lifting safety procedures.

Model	Weight Lbs/kgs	Model	Weight Lbs/kgs
3BA1300-7AT06	20/9	3BA1310-7AT26	33/15
2BA1300-7AT16	22/10	3BA1410-7AT36	55/25
3BA1400-7AT06	29/13	3BA1410-7AT46	59.5/29
3BA1400-7AT26	37.5/17	3BA1510-7AT46	86/39
3BA1500-7AT06	40/18	3BA1510-7AT56	97/44
3BA1500-7AT16	46.5/21	3BA1610-7AT26	104/47
3BA1500-7AT26	51/23	3BA1610-7AT36	119/54
3BA1500-7AT36	55/25	3BA1610-7AT46	163/74
3BA1600-7AT06	57.5/26	3BA1610-7AT56	172/78
3BA1600-7AT16	64/29	3BA1640-7AT36	128/58
3BA1600-7AT26	75/34	3BA1640-7AT46	172/78
3BA1600-7AT36	90.5/41	3BA1640-7AT56	181/82
3BA1800-7AT06	128/58	3BA1810-7AT16	250/113
3BA1800-7AT16	143/65	3BA1810-7AT26	260/118
3BA1800-7AT26	150/68	3BA1810-7AT36	316/143
3BA1900-7AT06	265/120	3BA1810-7AT46	341/155
3BA1900-7AT16	314/142	3BA1840-7AT26	260/118
		3BA1840-7AT36	316/143
		3BA1910-7AT16	409/186
		3BA1910-7AT36	455/206
3BA7210-0AT167	35.3/16	3BA7220-0AT567	61.7/28
3BA7310-0AT167	35.3/16	3BA7320-0AT567	66.1/30
3BA7410-0AT167	50.7/23	3BA7420-0AT267	72.7/33
3BA7510-0AT168	57.3/26	3BA7420-0AT567	86/39
3BA7510-0AT268	63.9/29	3BA7520-0AT268	88.2/40
3BA7610-0AT168	70.5/32	3BA7620-0AT368	106/48
3BA7610-0AT368	77.2/35	3BA7620-0AT568	143/65
		3BA7630-0AT668	207/94

When lifting 3BA15 through 3BA19 (but not 3BA1943 units) or the 3BA75 through the 3BA76, use the eye bolt provided (eye bolts are not included on smaller units). One attachment point should be sufficient. Ensure that the crane is rated for the weight being lifted.

For the 3BA1943, use the eye bolt and the holes in the feet of the blower to lift and maintain a balanced load.

### **Storage**

The 3BA units should be stored in a clean, dry environment. If stored in an area with a humidity of greater than 80 percent, store in a closed container with desiccant drying agents to avoid damage.

### **Disposal**

Dispose in accordance with all local health and safety regulations.

Spare parts list are available from your local Airtech service center. Please contact your local Airtech representative for assistance.

For additional assistance, please contact:

Airtech, Inc.,  
150 South Van Brunt Street  
Englewood, NJ, 07631  
Phone: 1-201-569-1173  
Fax: 201-569-1696.

# 3BA1 SINGLE STAGE EXPLODED VIEW

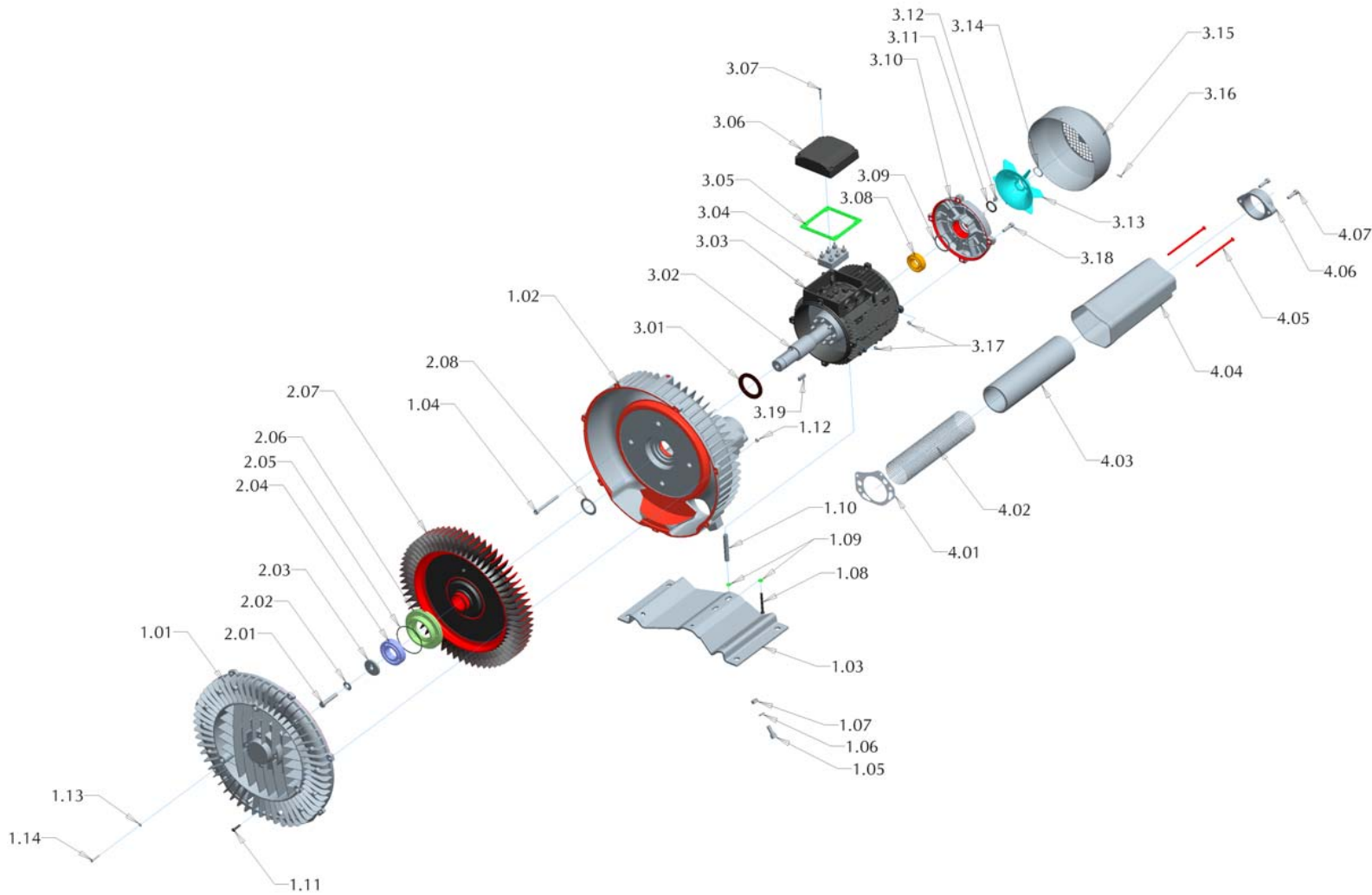

No.	Qty.	Description
1.01	1	Cover
1.02	1	Housing
1.03	1	Mounting Plate
1.04	4	Motor Mounting Screw
1.05	2	Mounting Plate Screw
1.06	2	Mounting Plate Washer
1.07	2	Mounting Plate Nut
1.08	1	Stator Support Screw
1.09	2	Stator Support Washer
1.10	1	Stator Support Sleeve
1.11	8	Cover Mounting Screw
1.12	8	Cover Mounting Nut
1.13	4	Bearing Cover Washer
1.14	4	Bearing Cover Screw
2.01	1	Shaft Screw
2.02	1	Shaft Lock Washer
2.03	1	Disc
2.04	1	Bearing
2.05	1	Bearing Cover O-Ring
2.06	1	Bearing Cover
2.07	1	Impeller
2.08	1	Disc
3.01	1	Seal
3.02	1	Motor Rotor
3.03	1	Stator
3.04	1	Terminal Block
3.05	1	Motor Terminal Box Gasket
3.06	1	Cover For Terminal Box
3.07	4	Terminal Box Cover Screw
3.08	1	Rear Bearing
3.09	1	Bearing Preloading Ring
3.10	1	End Shield
3.11	1	Tolerance Ring
3.12	1	Shaft Key
3.13	1	External Fan
3.14	1	Retaining Ring
3.15	1	Fan Cowl
3.16	4	Fan Cowl Screw
3.17	8	Stator Nut
3.18	4	End Shield Screw
3.19	1	Parallel Key
4.01	2	Silencer Gasket
4.02	2	Silencer Insert
4.03	2	Silencer Insert Filler
4.04	2	Silencer Casing
4.05	4	Silencer Screw
4.06	2	Flange
4.07	4	Flange Screw

# 3BA1 TWO STAGE EXPLODED VIEW

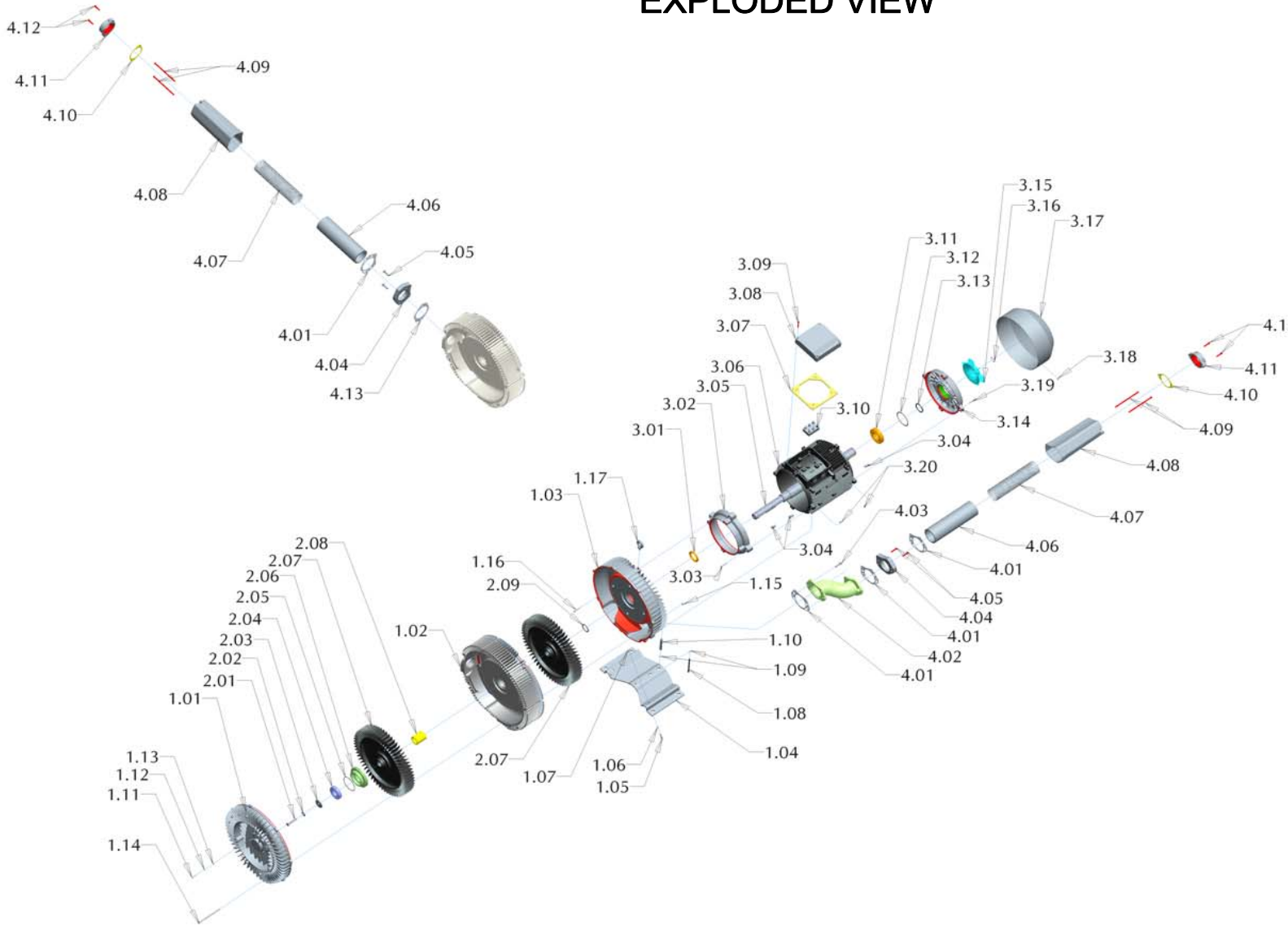

No.	Qty.	Description
1.01	1	Cover
1.02	1	Center Section
1.03	1	Blower Housing
1.04	1	Mounting Plate
1.05	2	Plate Mounting Screw
1.06	2	Mounting Plate Washer
1.07	2	Mounting Plate Nut
1.08	1	Stator Support Screw
1.09	2	Stator Support Washer
1.10	1	Stator Support Sleeve
1.11	4	Bearing Cover Screw
1.12	4	Bearing Screw Washer
1.13	4	Bearing Ring Seal
1.14	8	Cover Mounting Screw
1.15	8	Cover Mounting Nut
1.16	4	Motor Mounting Screw
1.17	1	Lifting Ring
2.01	1	Shaft Screw
2.02	1	Shaft Lock Washer
2.03	1	Disc
2.04	1	Bearing
2.05	1	Bearing Cover O-Ring
2.06	1	Bearing Cover
2.07	2	Impeller
2.08	1	Sleeve
2.09	1	Disc
3.01	1	Shaft Seal Ring
3.02	1	Motor Attachment
3.03	4	Motor Attachment Screw
3.04	3	Parallel Key
3.05	1	Motor Rotor
3.06	1	Stator
3.07	1	Motor Terminal Box Gasket
3.08	1	Cover For Terminal Box
3.09	4	Terminal Box Cover Screw
3.10	1	Terminal Block
3.11	1	Rear Bearing
3.12	1	End Shield Seal
3.13	1	Rotary Shaft Lip Seal
3.14	1	End Shield
3.15	1	External Fan
3.16	1	Retaining Ring
3.17	1	Fan Cowl
3.18	4	Fan Cowl Screw
3.19	4	End Shield Screw
3.20	8	Stator Nut
4.01	4	Silencer Gasket
4.02	1	Silencer Attachment
4.03	2	Silencer Attachment Screw
4.04	2	Silencer Flange
4.05	4	Silencer Flange Screw
4.06	2	Silencer Insert Filler
4.07	2	Silencer Insert
4.08	2	Silencer Casing
4.09	4	Silencer Screw
4.10	2	Flange Gasket
4.11	2	Flange
4.12	4	Flange Screw
4.13	1	Side Silencer Gasket



# 3BA7 SINGLE STAGE EXPLODED VIEW

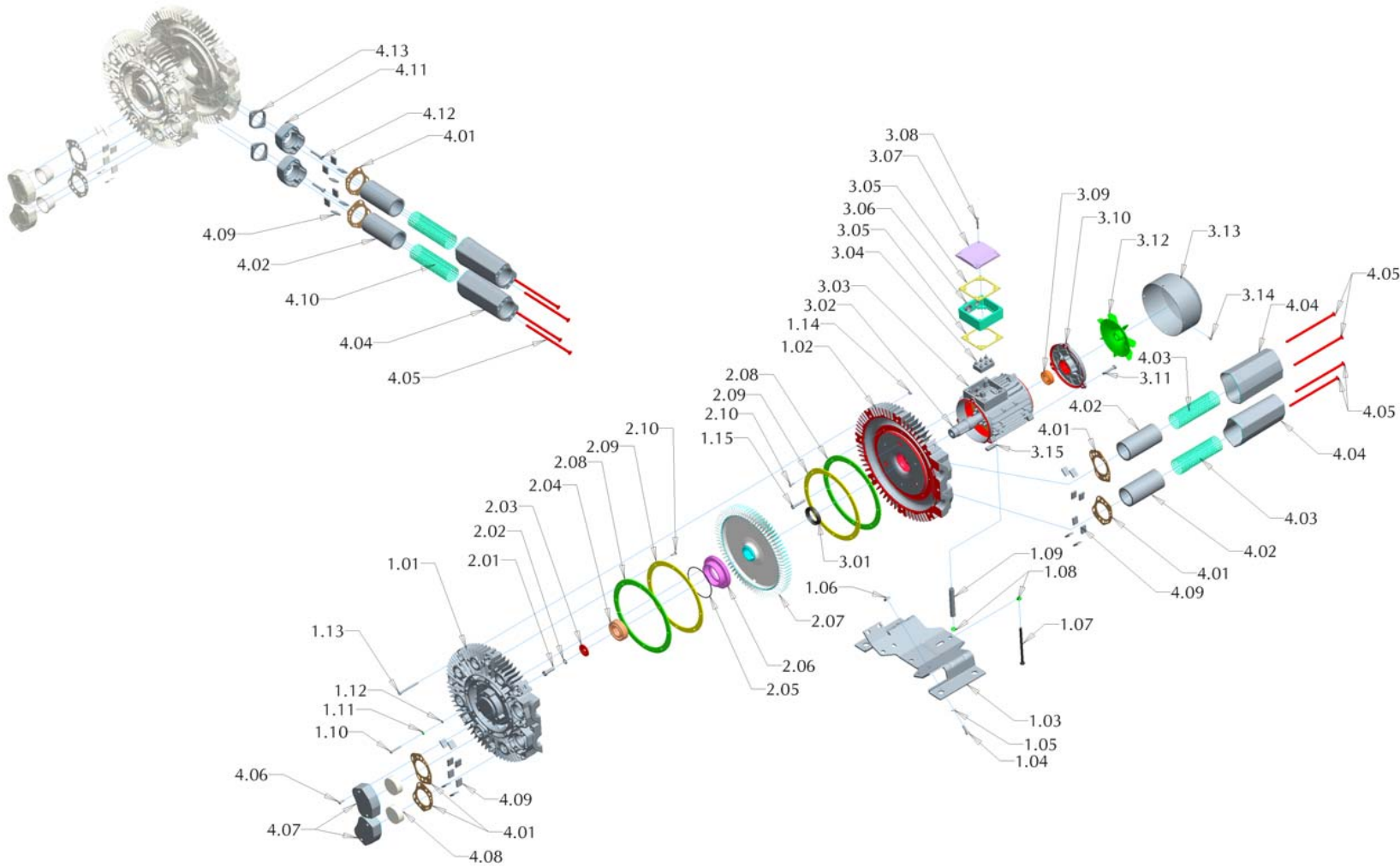

No.	Qty.	Description
1.01	1	Cover
1.02	1	Housing
1.03	1	Mounting Plate
1.04	4	Plate Mounting Screw
1.05	4	Mounting Plate Washer
1.06	4	Mounting Plate Nut
1.07	1	Stator Support Screw
1.08	2	Stator Support Washer
1.09	1	Stator Support Sleeve
1.10	3	Bearing Cover Screw
1.11	3	Bearing Screw Washer
1.12	3	Bearing Ring Seal
1.13	8	Cover Mounting Screw
1.14	8	Cover Mounting Nut
1.15	3	Motor Mounting Screw
2.01	1	Shaft Screw
2.02	1	Shaft Lock Washer
2.03	1	Disc
2.04	1	Bearing
2.05	1	Bearing Cover O-Ring
2.06	1	Bearing Cover
2.07	1	Impeller
2.08	2	Teflon Seal
2.09	2	Retaining Ring
2.10	16	Inner Seal Screw
3.01	1	Shaft Seal Ring
3.02	1	Motor Rotor
3.03	1	Stator
3.04	1	Terminal Block
3.05	2	Motor Terminal Box Gasket
3.06	1	Terminal Box
3.07	1	Cover For Terminal Box
3.08	4	Terminal Box Cover Screw
3.09	1	Rear Bearing
3.10	1	End Shield
3.11	3	End Shield Screw
3.12	1	External Fan
3.13	1	Fan Cowl
3.14	4	Fan Cowl Screw
3.15	1	Parallel Key
4.01	4	Silencer Gasket
4.02	2	Silencer Insert Filler
4.03	2	Silencer Insert
4.04	2	Silencer Casing
4.05	4	Silencer Screw
4.06	4	Flange Screw
4.07	2	Flange Cap
4.08	2	Flange Filler
4.09	16	Filler
4.10	2	Silencer Insert
4.11	2	Flange
4.12	4	Flange Screw
4.13	2	Flange Gasket

# 3BA7 TWO STAGE EXPLODED VIEW

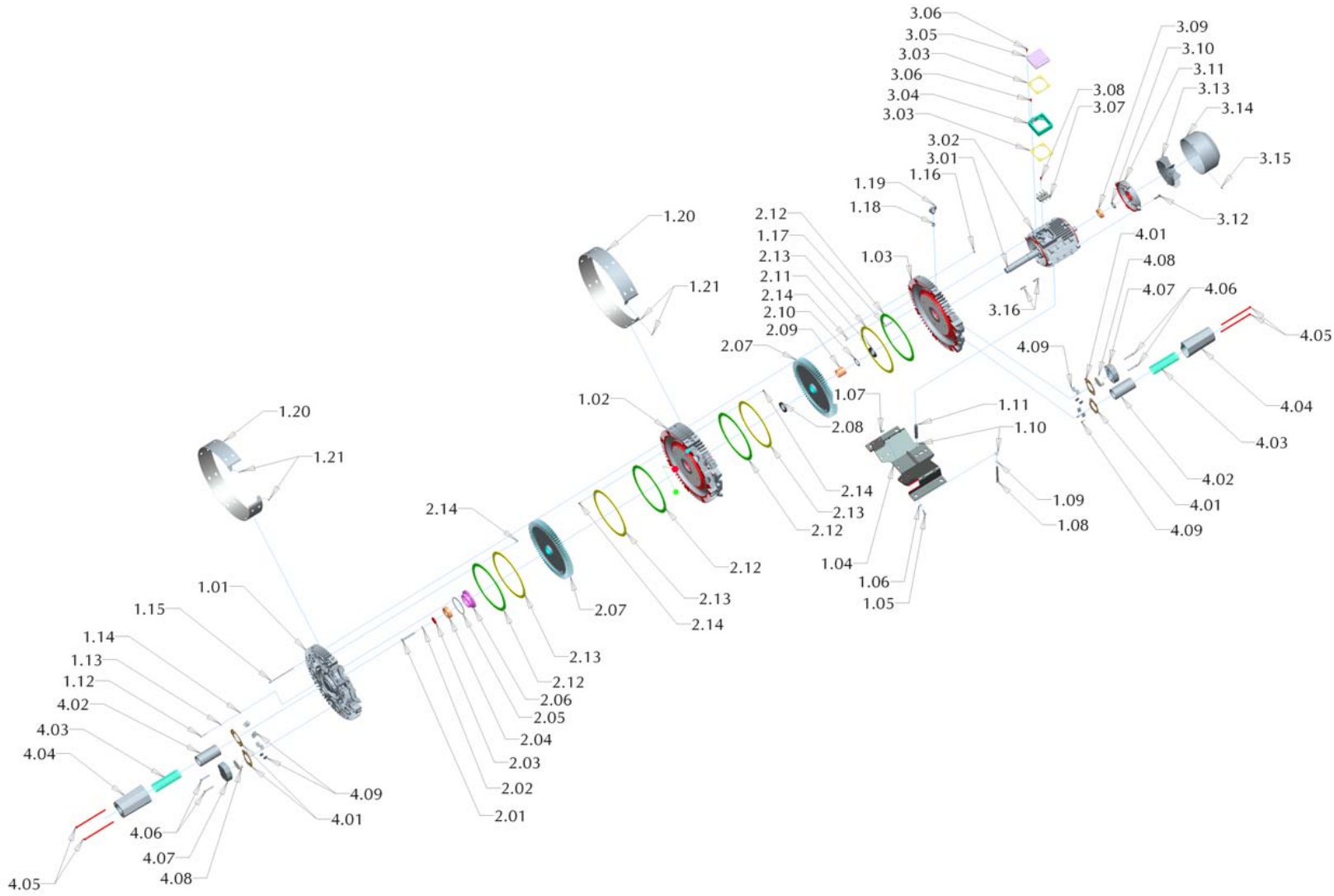

No.	Qty.	Description
1.01	1	Cover
1.02	1	Center Section
1.03	1	Housing
1.04	1	Mounting Plate
1.05	4	Plate Mounting Screw
1.06	4	Mounting Plate Washer
1.07	4	Mounting Plate Nut
1.08	1	Stator Support Screw
1.09	1	Stator Support Lock Washer
1.10	2	Stator Support Washer
1.11	1	Stator Support Sleeve
1.12	3	Bearing Cover Screw
1.13	3	Bearing Screw Washer
1.14	3	Bearing Ring Seal
1.15	8	Cover Mounting Screw
1.16	8	Cover Mounting Nut
1.17	4	Motor Mounting Screw
1.18	1	Lifting Ring Nut
1.19	1	Lifting Ring
1.20	2	Blower Cowl
1.21	4	Blower Cowl Screw
2.01	1	Shaft Screw
2.02	1	Shaft Lock Washer
2.03	1	Disc
2.04	1	Bearing
2.05	1	Bearing Cover O-Ring
2.06	1	Bearing Cover
2.07	2	Impeller
2.08	1	Rotary Shaft Seal
2.09	1	Sleeve
2.10	1	Disk
2.11	1	Shaft Seal Ring
2.12	4	Teflon Seal
2.13	4	Retaining Ring
2.14	32	Inner Seal Screw
3.01	1	Motor Rotor
3.02	1	Stator
3.03	2	Motor Terminal Box Gasket
3.04	1	Terminal Box
3.05	1	Cover For Terminal Box
3.06	8	Terminal Box Screw
3.07	1	Terminal Block
3.08	1	Terminal Block Screw
3.09	1	Rear Bearing
3.10	1	End Shield Disk
3.11	1	End Shield
3.12	4	End Shield Screw
3.13	1	External Fan
3.14	1	Fan Cowl
3.15	4	Fan Cowl Screw
3.16	2	Parallel Key
4.01	4	Silencer Gasket
4.02	2	Silencer Insert Filler
4.03	2	Silencer Insert
4.04	2	Silencer Casing
4.05	4	Silencer Screw
4.06	4	Flange Screw
4.07	2	Flange Cap
4.08	2	Flange Filler
4.09	16	Filler

## **Airtech, Inc. (“Company”) Warranty Statement**

Company warrants that on the date of shipment to Purchaser the goods will be of the kind and quality described herein, merchantable, and free of all defects in workmanship and materials.

If within one year from the date of initial operation, but not more than eighteen months from date of shipment by the Company, of any item of the goods, Purchaser discovers that such item was not as warranted above and promptly notifies Company in writing thereof, Company shall remedy such defect by, at the Company’s option, adjustment, repair or replacement of the item and any affected part of the good. Purchaser shall assume all responsibility and expense for removal, reinstallation and freight in connection with the foregoing remedy. The same obligations and conditions shall extend to replacement items furnished by the Company hereunder. Company shall have the right of disposal of items replaced by it. Purchaser shall grant Company access to the goods at all reasonable times in order for Company to determine any defect in the goods. In the event that adjustment, repair or replacement does not remedy the defect, the Company and Purchaser shall negotiate in good faith an equitable adjustment in the contract price.

The Company’s responsibility does not extend to any item of the goods which has not been manufactured and sold by the Company. Such item shall be covered only by the express warranty, if any, by the manufacturer thereof. The Company and its suppliers shall also have no responsibility if the goods have been improperly stored, handled or installed, or if the goods have not been operated or maintained according to their ratings or according to the instructions in Company or supplier furnished manuals, or if unauthorized repairs or modifications have been made to the goods.

**THIS WARRANTY IS EXPRESSLY IN LIEU OF ALL OTHER WARRANTIES (EXCEPT TITLE) INCLUDING BUT NOT LIMITED TO IMPLIED WARRANTIES OF MERCHANTABILITY AND FITNESS, AND CONSTITUTES THE ONLY WARRANTY OF COMPANY WITH RESPECT TO THE GOODS.**

The forgoing states Purchaser’s exclusive remedy against Company and its suppliers for any defect in the good or for failure of the goods to be as warranted, whether Purchaser’s remedy is based on contract, warranty, failure of such remedy to achieve its essential purpose, tort (including negligence), strict liability, indemnity, or any other legal theory, and whether arising out of warranties, representations, instructions, installations, or defects from any cause.

Neither Company nor its suppliers shall be liable, whether in contract, warranty, failure of a remedy to meet its essential purpose, tort (including negligence), strict liability, indemnity or any other legal theory, for loss of use, revenue or profit or for cost of capital or of substitute use or performance or for indirect, liquidated, incidental or consequential damages or for any other loss or cost of a similar type, or for claims by Purchaser for damages of Purchaser’s customers.

**AIRTECH<sup>®</sup>**  
VACUUM

150 South Van Brunt St.  
Englewood, NJ 07631  
Tel: 1-888-222-9940  
Fax: 201-569-1696  
airtech@airtechusa.com

**AIRTECH<sup>®</sup>** SOUTH  
VACUUM

2211 Newmarket Parkway  
Marietta, GA 30067  
Tel: 770-690-0700  
Fax: 770-690-0709  
airtechsouth@airtechusa.com

**AIRTECH<sup>®</sup>** WEST  
VACUUM

42 Digital Drive #9  
Novato, CA 94949  
Tel: 415-382-9000  
Fax: 415-382-9700  
airtechwest@airtechusa.com

**AIRTECH<sup>®</sup>**  
CHINA

2nd Building,  
Jiangbian Second Industrial Park  
Songgang Town, Bao'an District  
Shenzhen, China  
Tel: +86-755-81730991(Ext.8018)  
Fax: +86-755-81730986  
www.airtechchina.com



7 / 9 Sainsbury Road  
O'Connor 6163  
Australia  
Tel: +61 8 9331 4890  
Fax: +61 8 9331 4813  
www.vacuvane.com.au



Amsterdamstraße 16  
D-97424 Schweinfurt,  
Germany  
Tel: +49 (0)9721 94563-0  
Fax: +49 (0)9721 94563-29  
www.vacuvane.com



c/ dels amics d'Argentona, 40  
08310 Argentona (Barcelona)  
Spain  
Tel: (+34) 93 797 17 66  
Fax: (+34) 93 797 17 54  
www.hpe-technology.com