



## Hopper Separators

AutoVac's Hopper Separators are the ultimate filtration devices for large central vacuum systems. They effectively separate high volumes of debris from your system's airflow and deposit waste into convenient portable drums. Our hopper separators are available in several sizes and can be equipped as Primary Separators or Pulse Jet Separators depending on your application.

With **Primary Hopper Separators**, "dirty" air is pulled through vacuum hoses and piping and then directly into the separator. Debris passes around a precisely engineered baffle and then drops out of the airstream through centrifugal action. Debris drops into a portable drum while air and any remaining particles move on to the next filtration device (typically a separator equipped with filter bags).

**Pulse Jet Hopper Separators** separate debris from the airstream two ways. First "dirty" air passes through a cyclonic chamber that forces debris downward and into a collection drum. Air and remaining particles then pass through a second chamber equipped with filter bags. These filter bags typically capture between 95% and 99% of particles at 3 microns. Pneumatic valve timers periodically send powerful bursts of air into the filter chamber to break apart collected debris and send it into the collection drum.

AutoVac's team of professionals will help you select the proper filtration devices from our existing models and sizes – or we can design a custom hopper separator to suit your exact requirements.



888-628-8682

email: [sales@auto-vac.com](mailto:sales@auto-vac.com) • [www.auto-vac.com](http://www.auto-vac.com)

## Primary Hopper Separators

**JUMBO**  
**SUPER**  
**STANDARD**

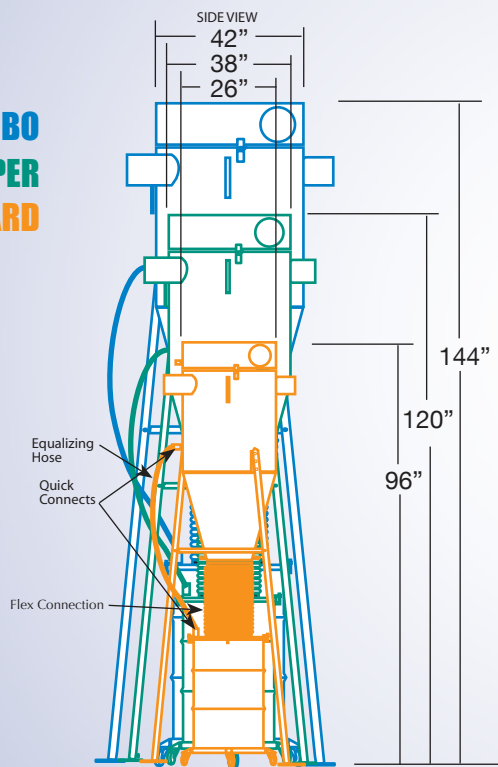

SEPARATOR	Dimensions	Weight	Inlet & Outlet Size	Order #
STANDARD	26 x 96"	975 lbs.	4" / 6"	324-5001
SUPER	38 x 120"	1125 lbs.	6" / 6"	326-5001
JUMBO	42 x 144"	1250 lbs.	6" / 6"	326-5002

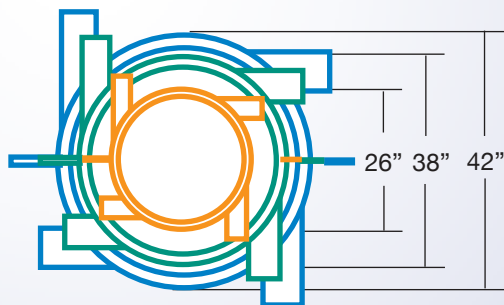

## Pulse Jet Hopper Separators

**JUMBO**  
**SUPER**  
**STANDARD**

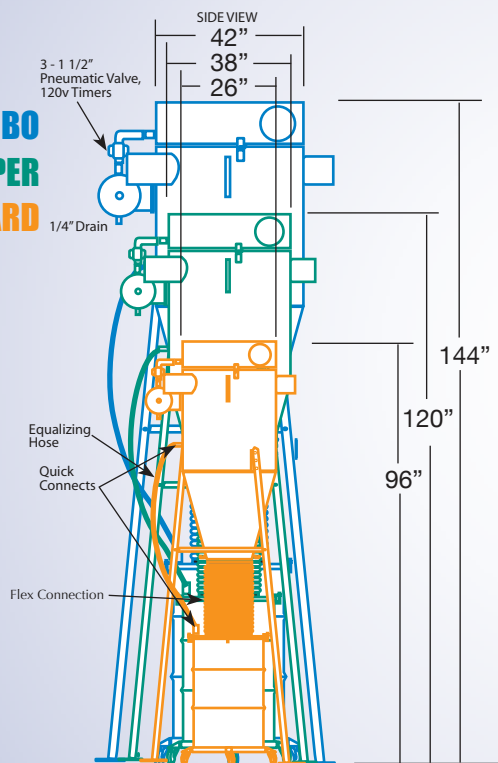

SEPARATOR	Dimensions	Weight	Inlet & Outlet Size	Order #
STANDARD	26 x 96"	1150 lbs.	4" / 4"	314-7001
SUPER	38 x 120"	1375 lbs.	6" / 6"	316-5001
JUMBO	42 x 144"	1450 lbs.	6" / 6"	316-5002

