

FILTRATION



Filter Separators

AutoVac filter separators are engineered and manufactured under exacting production standards to provide superior filtration. Each filter separator combines centrifugal action with the dust-trapping feature of stocking-type filter bags. As your vacuum producer creates suction it pulls air, dirt and debris from the end user's nozzle, through the vacuum hose, and into the lower half of the filter separator. Here, a precisely engineered cone creates a powerful cyclone that guides debris downward into a waste container. The air then passes through a series of filter bags contained in the upper portion of the filter separator. A properly sized filter separator with appropriate filter bags will collect 99.9% of debris at three microns – allowing only clean dry air to pass through the vacuum producer. The result? The most reliable central cleaning system available. See reverse to select the right filter separator for your system.



888-628-8682

email: sales@auto-vac.com • www.auto-vac.com

Filter Separators

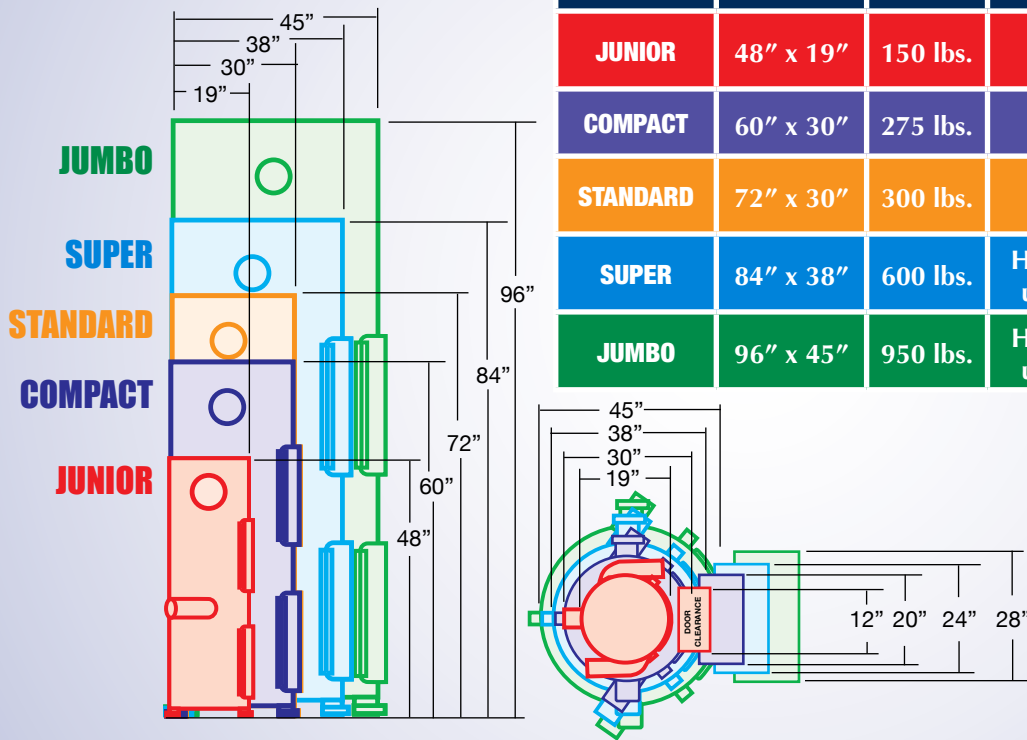

SEPARATOR	Dimensions	Weight	Recommended Vacuum	Inlet & Outlet Sizes	Order #
JUNIOR	48" x 19"	150 lbs.	RailVac Jr System	3"	313-1001
COMPACT	60" x 30"	275 lbs.	RailVac	4"	314-3001
STANDARD	72" x 30"	300 lbs.	Liberty or Gemini	4"	314-1002
SUPER	84" x 38"	600 lbs.	High AirFlow up to 60HP	6"	316-2002
JUMBO	96" x 45"	950 lbs.	High AirFlow up to 90HP	6"	316-3001

EQUIPMENT LAYOUT & PIPING CONNECTIONS FILTER SEPARATORS

- A. These lines carry dirt and debris from vacuum cleaning system, one or two lines as required.
- B. Vacuum producer inlet air and filter separator vacuum supply line.
- C. Additional vacuum producer may be connected here and must be same size.
- D. Hold down leg support 3 locations typical.
- E. Support pipe every 10 ft. minimum with an approved support hanger system. Never allow pipe to sag. Install hangers as needed. Sway brace as required.
- F. 3, 4, 6 or 8" dia. pipe respectively carries dirt from system. See pipe system drawings.

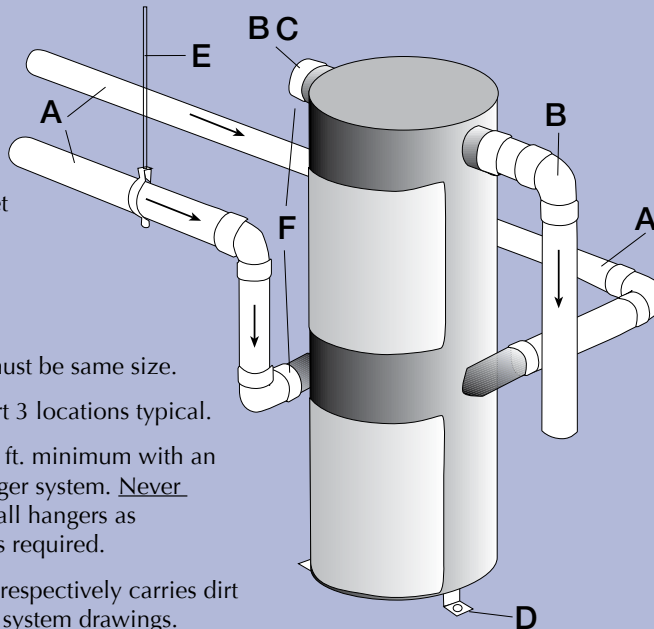

FEATURES AND BENEFITS

- Large durable polypropylene dirt bucket is virtually unbreakable and rust-proof.
- Internally glazed polyester filter bags eliminate clogging. No tools needed for fast removal and replacement.
- Leak-proof "U" channel door gasket with sealed air chamber expands and contracts keeping door panel leak-free.
- Lockable door latch assembly.
- All metal surfaces of separator are coated with industrial grade primer and automotive grade multi-part urethane top coat.
- 25-year proven design made from heavy grade iron, heavy gauge sheet steel and assembled with continuous welded seams.