

AUTOVAC
Industrial
Vacuum & Air Systems

*If it's not AUTOVAC,
it's just a copy!*

AUTO-VAC
serving the
auto care
industry for
23 years

**Nothing moves the air
like AUTOVAC.
Vacuum faster and cleaner
than the competition.**

**Exclusive
2 Year Motor
Warranty**



RAIL-VAC®

Strong, Durable, & Dependable

VISIT US ON THE WEB AT:
www.autovacinc.com

1-888-628-8682

email: sales@autovacinc.com

Our sleek, compact all-in-one RAIL-VAC includes muffler, rail frame, turbine, and filter separator. Mounted and plumbed as shown.

1. Isolator pads are included for easy installation. One pad under each support leg.

EXCLUSIVE

2. Heavy iron rail frame captures blower assembly, filter separator and motor pedestal mount. With properly positioned support legs, turbine stays aligned for continuous, smooth performance.

EXCLUSIVE

3. Only AutoVac has it, an exclusive two-year motor warranty. Extremely durable TEFC drive motor is cast iron. Aligned at the factory for vibration-free operation. Turbine blower section does not require disassembly to service motor.

EXCLUSIVE

4. Two each, two bolt outboard industrial ABEC5 bearings support our exclusive Rifle-Barrel-Straight impeller shaft.

5. Turbine blower casing is housed between two 1/2" thick 356 alloy hardened aluminum inlet and outlet heads. Strong durable heads provide rigid non-flex mounting surface for two-bolt flanged bearings.

6. Clean air suction supply line connection from vacuum producer to filter separator. This air is filtered, keeping dirt and dust out of vacuum turbine.

7. 23 year proven design made from heavy grade iron, heavy gauge sheet steel and assembled with continuous welded seams.

3

2

5

4

6

7

8

9

10

14

11

13

VACUUM PRODUCER

8. Leak-proof "U" channel door gasket with sealed air chamber expands and contracts keeping door panel secure and leak free.

9. Internally glazed polyester filter bags eliminate clogging. No tools needed for fast removal and replacement.

10. All metal surfaces of turbine, separator and rail frame are coated with ship-grade epoxy primer and high-grade multi-part urethane top coat. This gives a quality paint finish.

11. Large durable light-weight polypropylene dirt bucket is virtually unbreakable and rust-proof.

EXCLUSIVE

12. Polyurethane state-of-the-art WE4 and Sure Flex split rubber drive couplings from motor to turbine drive shaft. Can be changed without removing motor.

13. Filter and debris access doors with continuous hinges and high strength aluminium clasps.

14. Dirt container seal eliminates debris and fallout in the dirt container section, 100% dirt and debris deposited directly into the dirt container, and centers dirt container into lower section.

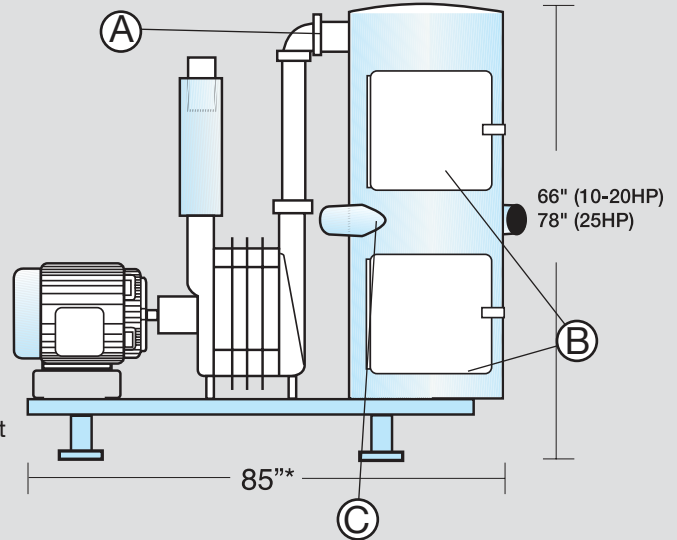
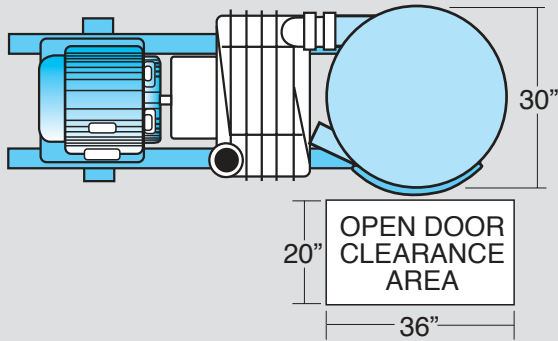

- A. One 4" tangential inlet pipe for connection to vacuum producer.
- B. Large steel access doors with one-piece hinge and adjustable draw tight latch assembly.
- C. Two - 4" or 6" optional intake connections.

* Slightly longer for 7 and 8 stage turbine models.

RAIL-VAC, TURBINE AND ELECTRICAL DATA

| RAIL-VAC MODEL # | 3 Phase TEFC Enclosed Motor Data | Line Volt AC | Full Load Amps | Total Copper Wire Size | Mag. Starter Size | Disconnect Non-Fused Rating in Amps | Circuit Breaker size in Amps | Aprox. Vac Hose Users | Complete Unit Weight |
|------------------|----------------------------------|--------------|----------------|------------------------|-------------------|-------------------------------------|------------------------------|-----------------------|----------------------|
| RV103B | 10HP 60HZ 3600 RPM | 208 | 32 | #8 | 1.5 | 60 | 60 | 3 - 4 | 900# |
| | | 230 | 28 | #8 | 1.5 | 60 | 50 | | |
| | | 460 | 14 | #12 | 1 | 30 | 30 | | |
| RV154B | 15HP 60HZ 3600 RPM | 208 | 48 | #6 | 2.5 | 60 | 100 | 4 - 5 | 1000# |
| | | 230 | 42 | #6 | 2 | 60 | 75 | | |
| | | 460 | 21 | #10 | 1.5 | 30 | 40 | | |
| RV205B | 20HP 60HZ 3600 RPM | 208 | 62 | #4 | 3 | 100 | 100 | 5 - 6 | 1100# |
| | | 230 | 54 | #4 | 2.5 | 100 | 100 | | |
| | | 460 | 27 | #8 | 2 | 60 | 60 | | |
| RV256B | 25HP 60HZ 3600 RPM | 208 | 78 | #3 | 3 | 100 | 150 | 6 - 7 | 1300# |
| | | 230 | 68 | #4 | 3 | 100 | 125 | | |
| | | 460 | 34 | #8 | 2 | 60 | 70 | | |

All Rail-Vac models are also available with explosion proof motors and 575 volt and 380 volt, 50 hertz. Contact your AutoVac representative for specifications and pricing.

RAIL-VAC SEPARATOR DATA

| SEPARATOR MODEL# | Type | Bag Replacement | Filter Bag Area | Filter Bags | Bag Dia. | Bag Length | Turbine Conn. | System Conn. | Dirt Bucket | Material | Wt. Lbs. |
|---|------------|-----------------|-----------------|-------------|----------|------------|---------------|-------------------------|-------------|-------------|----------|
| SF201Z For use with 10HP-20HP models | Filter Bag | R0503 | 29 sq. ft. | 10 | 6" | 22" | 1@4 | 2 @ 4 | 17 gal. | 12 ga Steel | 275 |
| SF101Z For use with 25HP models | Filter Bag | R0502 | 42 sq. ft. | 10 | 6" | 32" | 1@4 | 2 @ 4 or optional 2 @ 6 | 17 gal. | 12 ga Steel | 300 |

HOSE DROP KIT



This kit is required at every vacuum cleaning hose location and includes the following components:

- 1 15' x 1 1/2" hose with swivel cuffs
- 1 1 1/2" inlet valve
- 1 1 1/2" hose adapter
- 1 hose hanger assembly
- 1 1 1/2" vacuum cleaning nozzle

Typical hose drop kit shown here with a two drop, single lane set up.

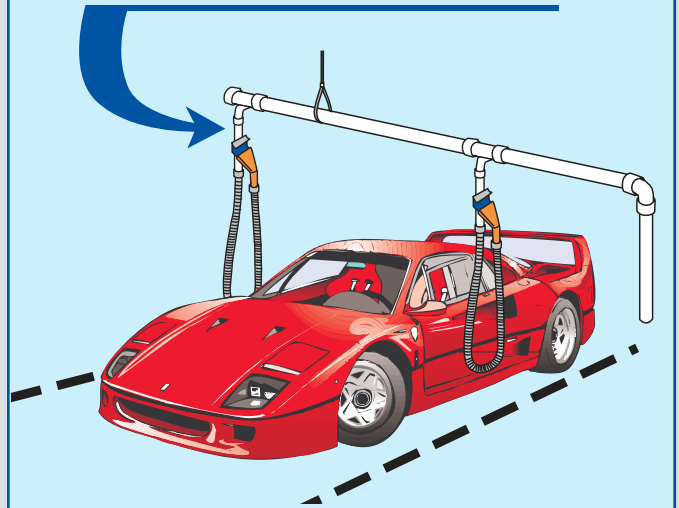

PIPING KITS

(plastic and steel available)

COIN CATCHER, Dirt Conveying Overhead Piping System Layout
1 Row, 6 hose, 3 Lane

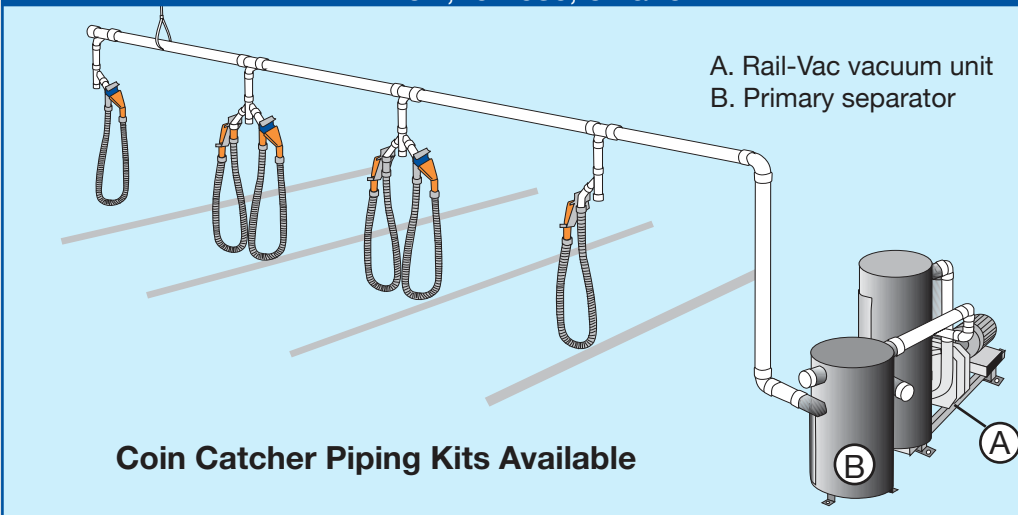

Coin Catcher Piping Kits Available

A. Rail-Vac vacuum unit
B. Primary separator

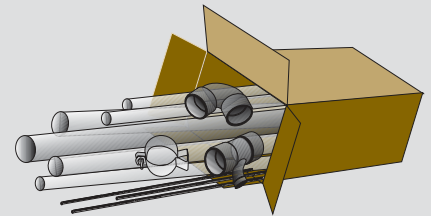

**Choose from
over 50 Kits**

All boxed and ready to install!

**High flow suction
performance all day,
every day with an
engineered piping kit
from AutoVac.**

AUTOVAC
Industrial
Vacuum & Air Systems

Toll Free: 1-888-628-8682

email: sales@autovacinc.com

website: www.autovacinc.com

Copyright © AVI Car Care LLC, 2012

REPRESENTED BY

